

# 200 GPD Floor-Mount Light Commercial Economy RO System



**Owners Manual**

---

## Table of Contents

---

Unpacking/Inspection .....	2
Safety Guide.....	2
Proper Installation.....	3
Introduction.....	3
Operation Overview and Parameters.....	4
System Safety.....	5
Rejection, Recovery and Flow Rates.....	5
System Components and Connections.....	6
System Dimensions.....	8
System Installation and Start-up Instructions.....	9
System Configuration Diagrams.....	12
Specifications Table.....	17
Operation and Maintenance.....	18
Flow Diagram.....	19
Electrical Diagram.....	20
Troubleshooting Guide.....	21
Warranty.....	22

### Unpacking / Inspection

Be sure to check the entire system for any shipping damage or parts loss. Also note damage to the shipping cartons. Contact H2O International Inc. to report any shipping damage within 24 hours of de-livery. Claims made after 24 hours may not be honored.

Small parts, needed to install the system, are in a parts bag. To avoid loss of the small parts, keep them in the parts bag until you are ready to use them.

### Safety Guide

- Check and comply with your provincial / state and local codes. You must follow these guidelines.
- Use care when handling the RO system. Do not turn upside down, drop, drag or set on sharp protrusions.
- **WARNING:** This system is not intended for treating water that is microbiologically unsafe or of unknown quality without adequate disinfection before or after the system. Contact US Water Systems for disinfection treatment equipment.

## Proper Installation

*This RO system must be properly installed and located in accordance with the Installation Instructions before it is used or the warranty will be void.*

- **Do not** install or store where it will be exposed to temperatures below freezing or exposed to any type of weather. Water freezing in the system will break it. Do not attempt to treat water over 100°F.
- **Do not** install in direct sunlight. Excessive sun or heat may cause distortion or other damage to non-metallic parts.
- Properly ground to conform with all governing codes and ordinances.
- Use only *lead-free solder and flux* for all sweat-solder connections, as required by state and federal codes.
- Maximum allowable inlet water pressure is 125 psi. If daytime pressure is over 80 psi, night time pressure may exceed the maximum. Use a pressure reducing valve to reduce the pressure.
- **WARNING:** Discard all unused parts and packaging material after installation. Small parts remaining after the installation could be a choke hazard.

## Introduction

The 200 GPD Light Commercial Floor Mount RO System is an economical solution for a light commercial RO system need. Industrial systems that can produce 200 GPD are typically three times the cost as this economy model. The 200 GPD floor mount RO system utilizes three 20" pre-filters and membranes that are designed to produce 200 GPD. This system can operate up to 97% rejection of incoming contaminants. The 200 GPD floor mount RO system is designed to be fed with a pressurized water source (40 PSI minimum). This allows the membrane to compress and to reject unwanted contaminants. The 200 GPD floor mount RO system is equipped with a hydraulic shutoff switch (ASO) to turn the RO on and off.

## Operation Overview and Parameters

### Operation Overview

A pressurized water source is fed to the first pre-filter which is a 5 micron spun poly sediment filter. The water then passes through the sediment filter to the carbon block filters. Water passes through the carbon block filters and then on to the membrane filters. Product water (permeate) from the membrane filters is conveyed to the automatic shutoff valve (ASO). Product water from the “Out” port on the ASO can then be attached to a tank or point of use. Waste water (concentrate) from the membrane is conveyed to the flow restrictor. The water leaving the flow restrictor is conveyed to an onsite drain.

### Operating Parameters

#### Operating Parameters Feed Water Requirements

\*\*If any of the feed water parameters are not within the limits given, consult US Water Systems for assistance.

Feed Temperature	40 - 85°F
System Inlet Pressure	30 - 80 PSIG
Maximum Operating Pressure (@77°F)	100 PSIG (Nominal)

Maximum SDI Rating	< 3
Maximum Turbidity	1 NTU
Maximum Free Chlorine and/or Chloramines	0 PPM
pH (continuous)	3 - 11
Hardness	< 1 GPG
Iron	<0.3 ppm
Manganese	<0.05 ppm
Total Dissolved Solids (TDS)	<1000 ppm

**NOTE: HIGHER TDS AND/OR LOWER TEMPERATURES WILL REDUCE THE SYSTEM'S PRODUCTION. 2% OF THE SYSTEM OUTPUT CAN BE LOST FOR EVERY DEGREE "F" BELOW 77.**

## System Safety

- **DO NOT USE WHERE THE WATER IS MICROBIOLOGICALLY UNSAFE OR OF UNKNOWN QUALITY WITHOUT ADEQUATE DISINFECTION BEFORE OR AFTER THE SYSTEM.**
- **PRETREATMENT MUST BE SUFFICIENT TO ELIMINATE CHEMICALS, ORGANICS OR INORGANICS THAT COULD ATTACK THE MEMBRANE MATERIAL**
- **ALWAYS SHUT OFF THE FEED WATER AND RELEASE THE PRESSURE BEFORE WORKING ON THE UNIT.**
- **NEVER ALLOW THE UNIT TO FREEZE OR OPERATE WITH A FEED WATER TEMPERATURE ABOVE 100°F.**

## Rejection, Recovery and Flow Rates

US Water Systems 200 GPD Economy Reverse Osmosis Systems are designed to produce permeate water at the capacities indicated by the suffix in the system's name under the aforementioned conditions. For example, the US Water Systems 200 GPD Reverse Osmosis System produces 200 gallons per day of permeate water at the listed operating test conditions.

The amount of total dissolved solids (TDS) rejected by the membrane is expressed as a percentage. For example, a 98.5% rejection rate means that 98.5% of total dissolved solids do not pass through the membrane. To calculate the % rejection, use the following formula:

$$\% \text{ Rejection} = [(\text{Feed TDS} - \text{Product TDS}) / \text{Feed TDS}] \times 100$$

Example:  $98.5\% = [(550 - 8.25) / 550] \times 100$

**NOTE: ALL TDS FIGURES MUST BE EXPRESSED IN THE SAME UNITS, TYPICALLY PARTS PER MILLION (PPM) OR MILLIGRAMS PER LITER (MG/L).**

US Water Systems 200 GPD Reverse Osmosis Systems are designed to reject up to 98.5% NaCl, unless computer projections have been provided or stated otherwise.

The amount of permeate water recovered for use is expressed as a percentage. To calculate % recovery, use the following formula:

$$\% \text{ Recovery} = (\text{Product Water Flow Rate} / \text{Feed Water Flow Rate}) \times 100$$

Example:  $28\% = (0.14 / 0.50) \times 100$

**NOTE: ALL FLOW RATES MUST BE EXPRESSED IN THE SAME UNITS, TYPICALLY GALLONS PER MINUTE (GPM).**

## System Components and Connections



## System Components and Connections

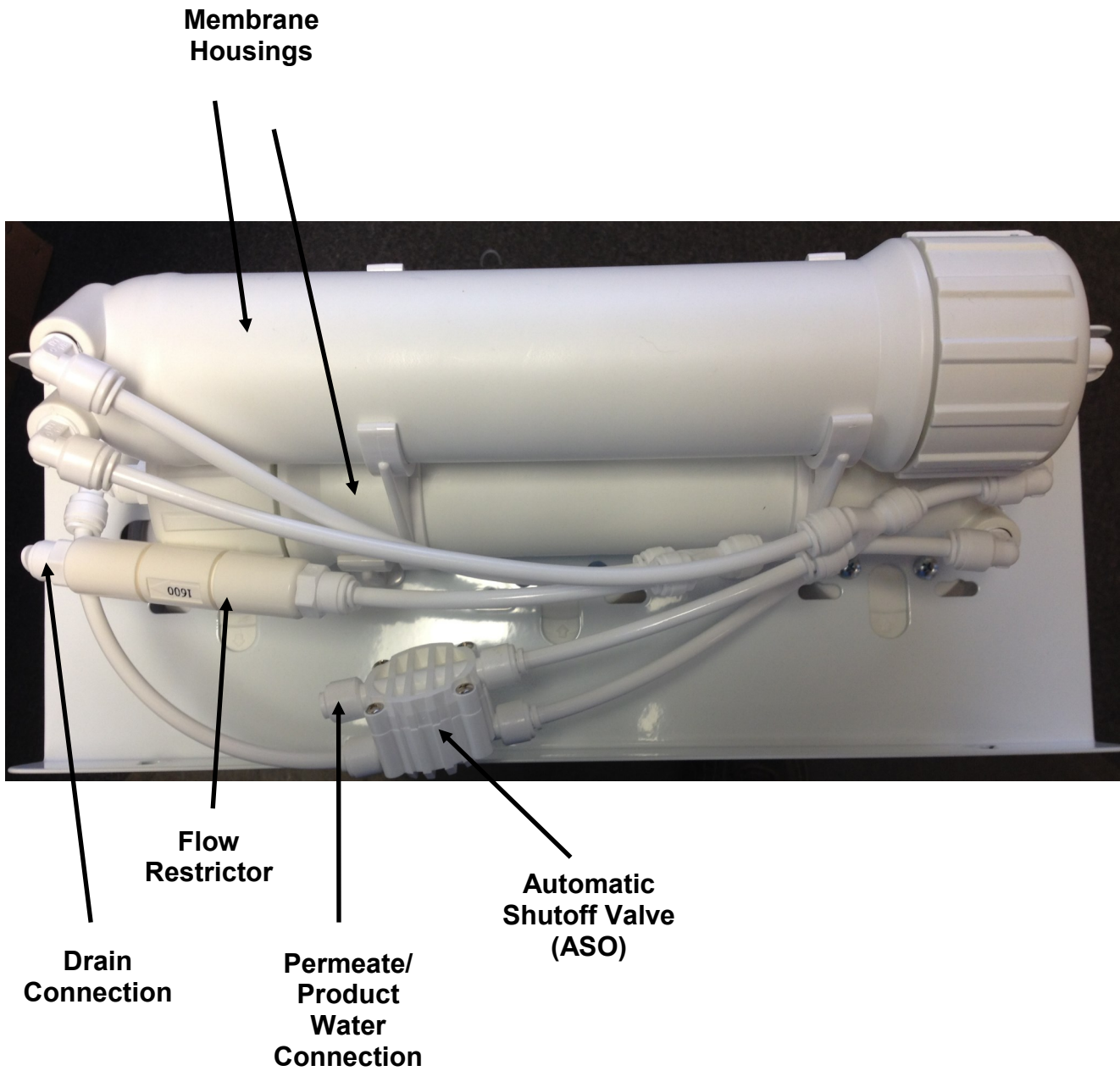

# System Dimensions

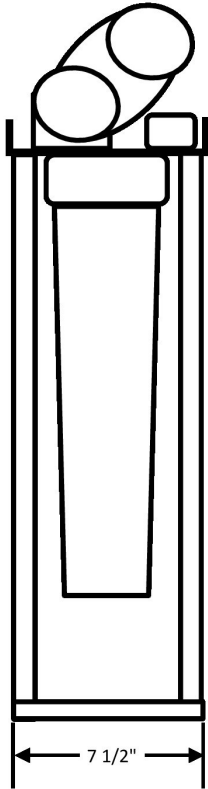
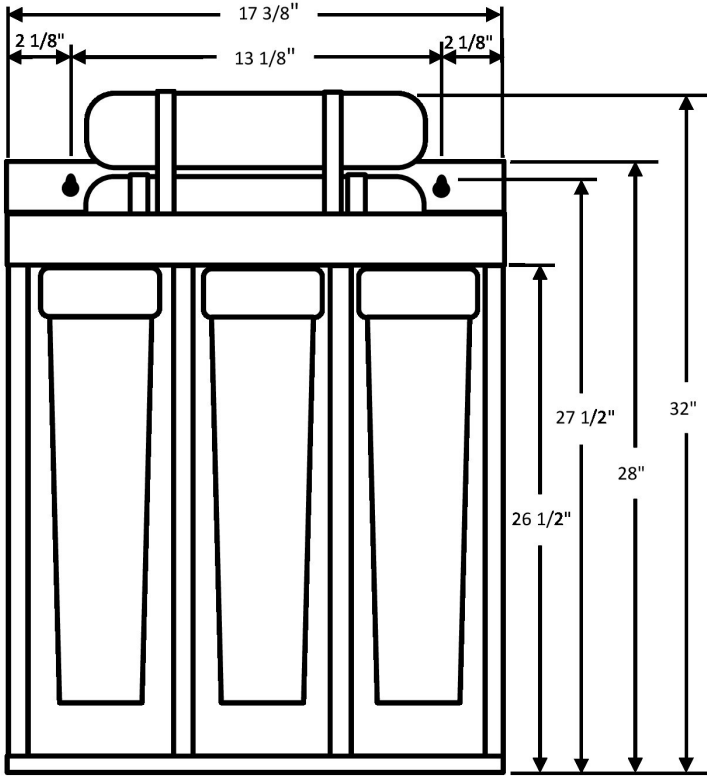

## System Installation and Start-up Instructions

1. Install the membranes in the membrane housings. By removing the 1/4" tubing from the cap side fittings.
2. Remove the membrane caps by turning them counterclockwise. BE SURE not to loose the O-rings when removing the caps. Each membrane housing is equipped with two O-rings.
3. Remove the membranes from the protective bag. Lubricate the two (2) O-rings on the end of the membrane center tube.
4. Install the membranes in the housing with the O-rings going in the housing first.
5. Fully seat the membrane in the housing. They should be inset about 1/8" in the housing when they are fully seated.
6. Lubricate the O-rings on the membrane housings and caps and re-install the caps by turning them clockwise until hand tight.
7. Re-attach the 1/4" tubing to cap side of the membranes.

**NOTE: THE PRE-FILTERS ARE FACTORY INSTALLED BUT THE SUMPS SHOULD BE CHECKED TO ENSURE THEY ARE TIGHT.**

## System Installation and Start-up Instructions

1. Inspect the system for any damage that could have occurred during shipment. Although all systems have been individually inspected, complete a quick inspection of the fittings, tubing and other components.
2. Please provide a reasonable amount of space for installation.

**NOTE: THE REVERSE OSMOSIS SYSTEM SHOULD BE INSTALLED INDOORS AND IT IS SUGGESTED THAT IT NOT BE IN DIRECT SUNLIGHT OR EXTREME COLD.**

3. Connect the 1/4" tube fitting to an incoming water source. The minimum feed water pressure should be at least 30 psi.



**NOTE: DO NOT OPERATE AT A PRESSURE EXCEEDING 100 PSI.**

4. Connect the concentrate 1/4" tubing (waste) line from the flow restrictor to drain.



## System Installation and Start-up Instructions

5. Convey the 1/4" permeate line to a drain to dispose of the initial flushing water from the membrane. This line will be attached to the tank later in the startup process.

**Permeate Line to Tank or Point of Use. Temporarily conveyed to a drain during startup.**



6. Turn on the feed water. Convey the permeate water to drain to flush the system.

**NOTE: THE AUTOMATIC SHUTOFF VALVE (ASO) WILL SHUT THE SYSTEM OFF AUTOMATICALLY WHEN THE BLADDER TANK IS FULL. IF A ATMOSPHERIC TANK IS USED, A ELECTRONIC FLOAT SWITCH SHOULD BE INSTALLED.**

7. Dispose of the initial product/permeate (clean) water until the TDS level/conductivity of the product water stabilizes at the lowest (cleanest) value. Use any TDS or Conductivity meter to monitor the product water quality. A minimum quality of 96% NaCl rejection is recommended (See the rejection rate calculation).
8. Once the system has been flushed and the TDS level has stabilized, the permeate/product line can be attached to the storage tank. Additional flushing of the storage tank and distribution system may be required to reach the TDS level that is produced directly after the RO system at all points of use.
9. This system is equipped with an ASO valve to shut the system at around 65% of the incoming line pressure. It is typical for the Permeate pressure to be 40% less than the feed pressure.

# Pressure Tank Configuration

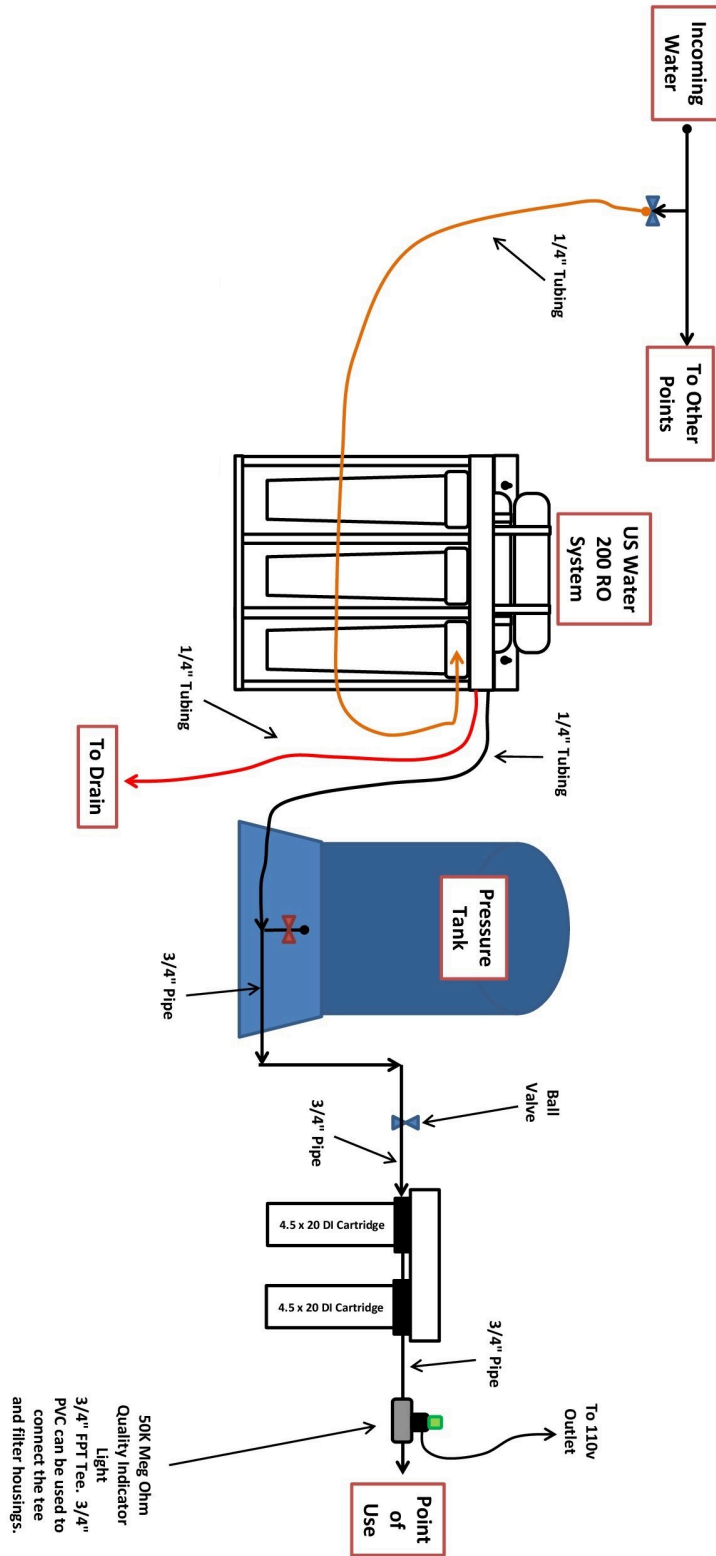

# Atmospheric Tank Configuration

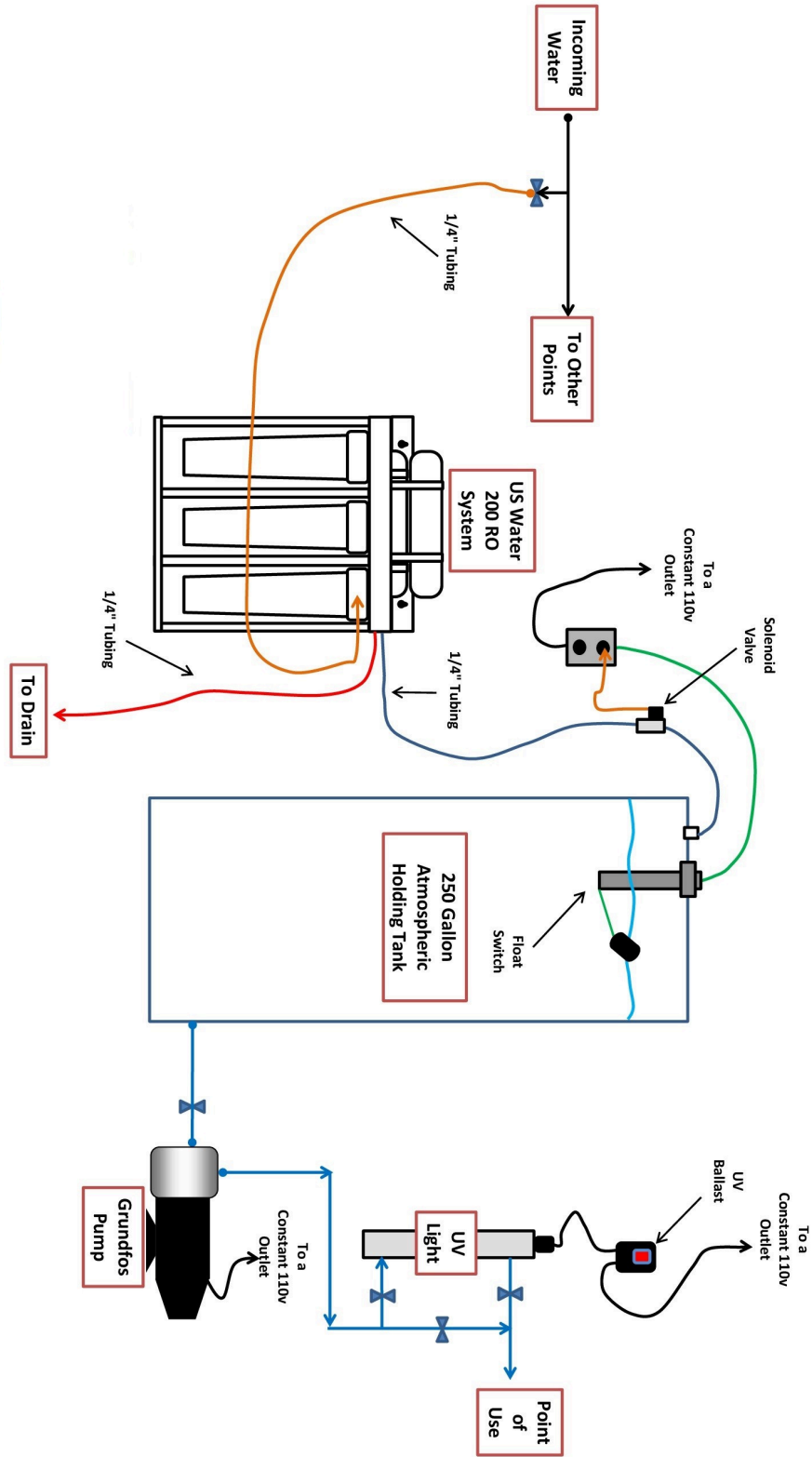

## Specifications

Parameter	Value
<b>DESIGN</b>	
Configuration	Single Pass
Feed Water Source	TDS <1000 ppm
<b>REJECTION AND FLOW RATES</b>	
Rejection	97-98.5 %
Permeate Flow Rate	0.13 GPM
<b>CONNECTIONS</b>	
Feed	1/4"
Permeate	1/4"
Concentrate	1/4"

## Operating Limits

Design Temperature	77° F	Max. Turbidity NTU	1
Max. Feed Temperature	85° F	Max. Free Chlorine ppm	0
Min. Feed Temperature	40° F	Mac. TDS ppm	<1,000
Max. Ambient Temperature	120° F	Max. Hardness GPG	<1
Min. Ambient Temperature	40° F	Max. pH (Continuous)	11
Max. Feed Pressure psi	80	Min. pH (Continuous)	3
Min. Feed Pressure psi	30	Iron ppm	<0.3
Max. Operating Pressure psi	100	Manganese ppm	<0.05
Max. SDI Rating	<3		

## Operation And Maintenance

The reverse osmosis process causes the concentration of impurities. The impurities may precipitate (come out of solution) when their concentration reaches saturation levels.

**NOTE: PRECIPITATION CAN SCALE OR FOUL MEMBRANES AND MUST BE PREVENTED.**

1. Periodically observe the quality and quantity of product water from the system.

**NOTE: CHECK THE FEED WATER PRESSURE GOING INTO THE REVERSE OSMOSIS MEMBRANE, A SIGNIFICANT DROP IN PRESSURE COULD INDICATE A FOULED PRE-FILTER.**

2. A 20% increase in TDS when checking the permeate water indicates possible membrane damage, and the membrane may need to be replaced.
3. It is suggested that a hand held TDS digital meter is used once per week to monitor the water quality.

**NOTE: IF THE TDS OF THE FEED WATER EXCEEDS 1000 PPM, A HIGHER FLOW RATE FLOW RESTRICTOR SHOULD BE USED TO EXTEND THE MEMBRANE LIFE.**

4. It is important to maintain and/or replace the carbon block regularly since the Thin Film Composite membranes are chlorine sensitive. Irreversible damage will occur with any chlorine present in the feed water.
5. The product line has a one way check valve installed.
6. Keep the feed water temperature above 4°C (36°F).

**NOTE: EXTREMELY COLD FEED WATER WILL LOWER THE PRODUCT WATER OUTPUT AND INCREASE PUMP PRESSURE.**

### ABNORMAL PERMEATE FLOW

Permeate flow should be within 20% of the rated production, after correcting the feed water temperatures above or below 77°F. There is a 2% loss in production for every degree below 77°F.

Example;

A 200 GPD system will produce 200 gallons in a 24 hour period at 77°F. If the water temperature is 52°F the equation is as follows;

$$77 - 52 = 25$$

$$25 \times 2\% = 50\%$$

So a 25° degree change in the feed water temperature will reduce the production of the RO by 50%. In this case a 200 GPD RO system may only produce 100 GPD.

### SERVICE ASSISTANCE

If service assistance is required, please complete the following process:

Contact H2O International Inc. prior to making the call, have the following information available: system installation date, current operating parameters (e.g. flow, operating pressures, pH, etc.) and a detailed description of the problem.

# Flow Diagram

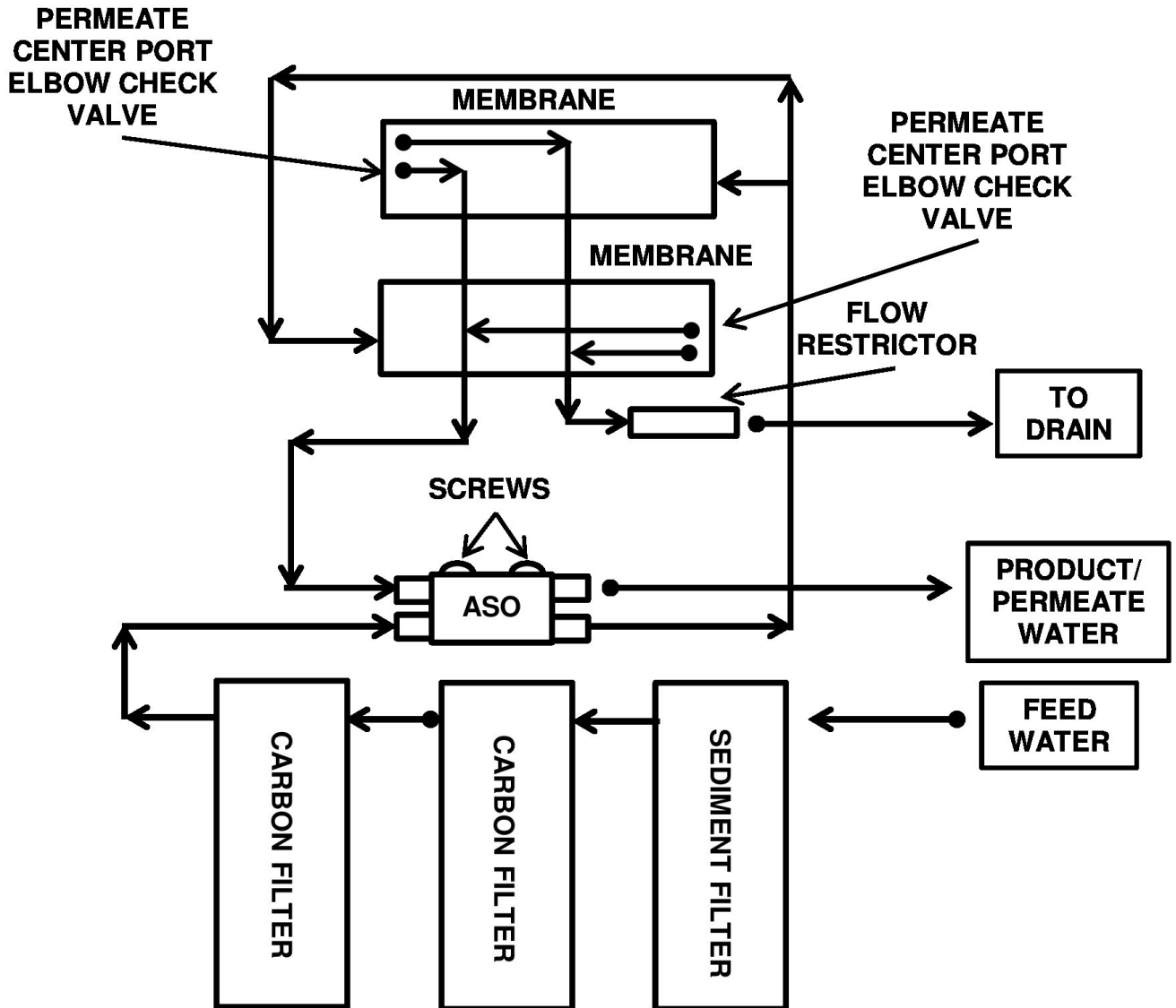

## Troubleshooting Guide

SYMPTOMS	POSSIBLE CAUSES	CORRECTIVE ACTION
Low Inlet Pressure	Low supply pressure	Increase inlet pressure
	Pre-filters plugged	Change filters
	Leaks	Fix any visible leaks
Low Permeate Flow	Cold feed water	See temperature correction sheet
	Low operating pressure	See low inlet pressure
	Defective membrane brine seal	Inspect and/or replace brine seal
	Fouled or scaled membrane	Clean membranes
High permeate flow	Damaged product tube o-rings	Inspect and/or replace
	Damaged or oxidized membrane	Replace membrane
	Exceeding maximum feed water temperature	See temperature correction sheet
Poor permeate quality	Low operating pressure	See low inlet pressure
	Damage product tube o-rings	Inspect and/or replace
	Damaged or oxidized membrane	Replace membrane
Membrane fouling	Metal Oxide Fouling	Improve pretreatment to remove metals.
	Colloidal Fouling	Optimize pretreatment for colloid removal.
	Scaling (CaSO <sub>4</sub> , CaSO <sub>3</sub> , BaSO <sub>4</sub> , SiO <sub>2</sub> )	Increase anti-scalant dosage for Ca-VO <sub>3</sub> and CaCO <sub>4</sub> . Reduce recovery.
	Biological Fouling	Replace cartridge filters.
	Organic Fouling	Activated Carbon or other pretreatment.
	Chlorine Oxidation	Check Chlorine feed equipment and de-chlorination system.
	Abrasion of membrane by Crystalline Material	Improve pretreatment. Check all filters for media.

# Warranty

For 1 year after the original purchase, at the original location of installation of this *Economy RO System, H2O International INC.* warrants the following:

## ONE YEAR COVERAGE

### RO Assembly & Electronics

We warrant that for one (1) year from the date of purchase, we will replace the RO assemblies and components at no charge to you except for transportation and standard labor charges. Electronics damaged due to environmental issues or improper installation are not covered. Consumables such as pre-filters and the membrane are not covered under this warranty.

## GENERAL PROVISIONS

This warranty does not apply to any commercial or industrial installations which has been subjected to misuse, neglect, alteration or accident; or to any damage caused by fire, flood, freezing, Acts of God, or any other casualty, or if the original serial numbers have been removed. RO systems that are operated out of design parameters will not be warranted.

These warranties are in lieu of all other warranties expressed, or implied, and we do not authorize any person to assume for us any other obligation on the sale of this RO system. No responsibility is assumed for delays or failure to meet these warranties caused by strike, government regulations or other circumstances beyond the control of H2O International Inc.

To obtain warranty service, call or write: H2O International Inc. 3001 SW 15th St, Deerfield Beach, FL, +1 954-570-3464

ANY IMPLIED WARRANTIES OF FITNESS OR MERCHANTABILITY ARE LIMITED TO THE TERMS OF THIS EXPRESSED WARRANTY AND THERE ARE NO WARRANTIES WHICH EXTEND BEYOND THOSE HEREIN. US WATER SHALL NOT BE LIABLE FOR ANY INCIDENTAL OR CONSEQUENTIAL DAMAGES.

Some states do not allow the exclusion or limitations of incidental or consequential damages so the above limitation may not apply. This warranty gives specific legal rights to the customer, and the customer may also have other rights which vary from state to state.

THIS WARRANTY MAY BE TRANSFERRED TO A SUBSEQUENT OWNER WITH WRITTEN APPROVAL OF US WATER AND PAYMENT OF STANDARD TRANSFER FEE.