



**REVERSE
OSMOSIS**
WATER PURIFICATION SYSTEM



**Installation Guide For
RO-300G & RO-600G**

I. Introduction	3
II. Identification of Components and Parts	3
III. System Specifications	4
IV. Reverse Osmosis Process Terminology	5
a. Water Quality	5
b. Rejection Ratio	5
c. Water Production Available	5
d. Percent Recovery	5
e. Water Pressure and Temperature	5
f. Permeate Flow	5
g. Request for Technical Assistance	5
V. Installation Instructions and Startup	6
VI. Operation and Maintenance	7
VII. Diagrams and Tank Configuration Options	8
a. Flowcharts	8
b. Pressure Tank Configuration	8
c. Atmospheric Tank Configuration	8
VIII. Quick Connectors	9
IX. Precautions and Tips	9
X. Operating Parameters	10
XI. Troubleshooting and Solutions Guide	10
XII. Liability and Warranty	12



WARNING: READ ENTIRE MANUAL. FAILURE TO FOLLOW ALL GUIDES AND RULES COULD CAUSE PERSONAL INJURY OR PROPERTY DAMAGE.



CHECK WITH YOUR STATE AND/OR LOCAL PUBLIC WORKS DEPARTMENT FOR PLUMBING CODES.



WARNING: DO NOT USE WITH WATER THAT IS MICROBIOLOGICALLY UNSAFE OR OF UNKNOWN QUALITY WITHOUT ADEQUATE DISINFECTION BEFORE OR AFTER THE SYSTEM.

NOTE: Failure to comply with these installation instructions will void the product Warranty, and the installer will be responsible for any service, repair or damages caused thereby.

I. INTRODUCTION

Your new water purifier works through a process called reverse osmosis in which water of a concentrated solution is applied pressure and forced through a semipermeable membrane for achieving a diluted pass across the membrane or low-salt solution.

When water passes through the membrane, dissolved minerals contained in the feed water as concentrated solution are rejected and sent to the drain.

The system is designed for low-salt purified water through 4 stages and we recommend it for domestic use and commercial to have water for drinking, cooking, preparing drinks, ice and food processing in general.

1. Pre-filtration up to 5 micron sediment particles removed by suspending
2. Pre-filtration cartridge coal block to remove chemical contaminants
3. Reverse osmosis membrane, which reduces total dissolved solids levels (TDS)
4. Post-filtration on activated carbon block to refine water taste .

This system automatically operates through several components: low pressure switch, solenoid valve, pump booster and switch high pressure, same as they are installed properly so that when a full tank of storage you have, the system shuts down and when no feed water pump switch has no team.

The RO-300G & RO-600G models are a basic version of a business osmosis model with attractive price and guarantees a salt retention of up to 97%.

Please be sure to read this manual before proceeding with the installation to become familiar with the terms and parties.

II. COMPONENTS IDENTIFICATION AND SPARE PARTS FOR MAINTENANCE

#	Description	Part Number	Model	
			300	600
1	Filter Housings	HF4-20WHWH38	3	3
2	Sediment Cartridge (5M)	SDC-25-2005	1	1
3	Carbon Block Cartridge	CB-25-2010	2	2
4	RO Membrane Housing	MH03-3012	1	2
5	RO Membrane	TW-3012	1	2
6	Booster Pump - Aquatrol	PMP-300GPD	1	2
7	Plastic Mounting Clip	CLP-30W	2	4
8	Low Pressure Switch	PMP-LPS14	1	1
9	Solenoid Valve (3/8")	BSV-38110V	1	1
10	High Pressure Switch	PMP-TSO14	1	1
11	Pressure Gauge 0-150 PSI	PG15150B	1	1
12	Quick connect Fittings	Several	1 kit	1 kit
13	Polyethylene tubing (3/8")	PT-6-WH-0500	1 kit	1 kit
14	Polyethylene tubing (1/4")	PT04-BL-0500	1 kit	1 kit
15	Feed Valve (3/8")	WNV-2	1	1
16	Filter Wrench	FW-1	1	1
17	RO housing wrench	FW-5	1	1
18	Pressure Regulator - Shok Blok	SB-FPV-60	1	1
19	Flow Restrictor	IFR-3000A	1	1
20	Check Valve - Hydrofit	HDF-ICV04	1	2
21	Inline Valve - Hydrofit	HDF-BVI04	1	1
22	Metal Bracket	Double level	1	1

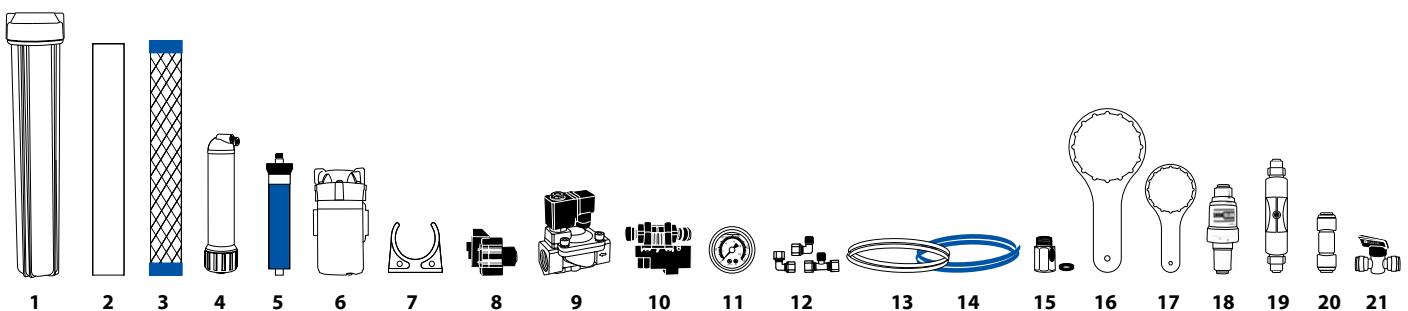

RO-300G & RO-600G

System Specifications

III. RO-300G & RO-600G SYSTEM SPECIFICATIONS:



WARNING! DO NOT USE WHERE THE WATER IS MICROBIOLOGICALLY UNSAFE OR OF UNKNOWN QUALITY WITHOUT ADEQUATE DISINFECTION BEFORE OR AFTER THE SYSTEM.



PRETREATMENT MUST BE SUFFICIENT TO ELIMINATE CHEMICALS, ORGANICS OR INOR-GANICS THAT COULD ATTACK THE MEMBRANE MATERIAL ALWAYS TURN OFF THE UNIT, SHUT OFF THE FEED WATER, AND DISCONNECT THE ELECTRICAL POWER BEFORE WORKING ON THE UNIT.



NEVER ALLOW THE PUMP TO RUN DRY.



NEVER ALLOW THE UNIT TO FREEZE OR OPERATE WITH A FEED WATER TEMPERATURE ABOVE 100°F.



WARNING! WARRANTY IS VOID AND COMPANY ASSUMES NO RESPONSIBILITY FOR SYSTEM OR PROPERTY DAMAGE IF THE SUPPLY PRESSURE IS OVER 80 PSI.



RO-300G



RO-600G

IV. REVERSE OSMOSIS PROCESS TERMINOLOGY

a. Water Quality:

Water quality from an RO system is normally determined with a TDS Meter, which measures total dissolved solids in water, measuring conductivity. The results are normally measured in parts per million or milligrams per liter. (ppm or mg/L) Fewer dissolved solids results in higher quality water.

b. Rejection Ratio:

The least amount of TDS means a higher water quality. Osmosis membranes are classified by the amount of total dissolved solids (minerals) refuse and are expressed as a percentage of rejection.

For example:

If feed water contains 100 ppm of dissolved solids and the product water after the membrane has 10 ppm of dissolved solids the rejection rate is 90%.

Formula:

$$\boxed{\text{Percent Rejection}} = \frac{(\text{Feed H}_2\text{O TDS} - \text{Product H}_2\text{O TDS})}{\text{Feed H}_2\text{O TDS}} \times 100$$

NOTE: All TDS data must be expressed in the same units, typically parts per million (PPM) or milligrams per liter (mg / L).

c. Water Production Available:

Each system is designed with an especific flow rate according to the size of the membrane(s) and it will be referencing the water production flow capable to produce.

This capacity is indicated as gallons per day in consideration of 24 hrs of operation.

The flow of water flowing into the drain is called wastewater and is measured in Gal/Day.

The feedwater flow is the sum of currents product water and waste water.

d. Percent Recovery:

It is another way to measure the amount of water produced compared to the amount of water used.

Formula:

$$\boxed{\text{Percent Recovery}} = \frac{\text{Product H}_2\text{O Rate}}{\text{Feed H}_2\text{O Rate}} \times 100$$

e. Water Pressure and Temperature:

Product water quality and production of RO systems is dependent on pressure and temperature. Typically, RO membranes are treated at standard conditions of 77 °F (25 °C) y a 100 PSI.

In general, the higher the pressure differential and temperature, the greater the quality and quantity of water produced.

These factors should be considered when sizing RO systems for a particular application.

f. Permeate Flow (variable)

Permeate flow should be within 20% of the rated production, after correcting the feedwater temperatures above or below 77 ° F.

For example:

5 gpm @ 59° F (5÷1.42=3.52 gpm)
 5 gpm @ 77° F (5÷1=5 gpm)
 5 gpm @ 84° F (5÷0.89=5.62 gpm)

g. Request for Technical Assistance

If service assistance is required, please complete the following process.

Contact your local dealer or distributor. Prior to making the call, have the following information available:

System installation date, series number, daily log sheets, current operating parameters (e.g. flow, operating pressures, pH, etc.) and a detailed description of the problem.

V. INSTALLATION AND STARTUP INSTRUCTIONS:

- System Location: Select a place with enough space to install your system close to an area where you have available potable water (cold line), drain and electrical power 120 V.
- Take out the box your system and identify all the components. Start placing RO membrane into the housing membrane. You can temporarily disconnect the tubing that feeds the input of RO housing cap threaded, using the wrench you can loosen the cap. Remove membrane from bag and place in the RO housing with the external oring directed towards the outer side of the cap.
- Tighten the cap with the wrench until get a good seal to prevent leakage. Return the RO housing to the main original position and put together tubing and connector removed.
- Install the feed valve's system, this will be placed in the supply line of cold water in your sink, place the pressure regulator about 2 ft from the water feed valve and scroll the tubing to where the purifying equipment is to be installed, place it on the system's feed that is at the entrance of the sediment filter.
- Make sure the filter holders are tight and also to make the circulation of its line of drainage where applicable. The drain line is the final connection of the membranes and waste water is high in salts minerals that should be discarded and not recommended to reuse this water to feed the system again and to cause serious damage to the membranes.
- Install the valve arrangement of purified water at the point of choice and also place the storage tank in its final position, then the hydraulic preparations corresponding thereto.
- Do not forget to place a key storage tank outlet that will help in future repairs and maintenance of their post-treatment to close the line of purified water.
- Before electrically connecting the system to make sure there are no leaks in the supply line opening the stopcock, if it detects any leakage repair it before continuing.
- Let the water flow for at least 5 minutes before electrically connecting the equipment to ensure that the holder filled with water pre-treatment and also be releasing the air the system.
- We recommend starting at first produce osmosis water allowing free passage for the connections to check that there is no leakage in their connectors which should keep the key final disposition open and close the tap of the tank. The water began to come out of the faucet until it fills before the post-carbon filter and that can take up to 5 minutes.
- Dispose of the initial product/permeate (clean) water until the TDS level/conductivity of the product water stabilizes at the lowest (cleanest) value. Use any TDS or Conductivity meter to monitor the product water quality. Once the system has been flushed and the TDS level has stabilized, the permeate/product line can be attached to the storage tank. Additional flushing of the storage tank and distribution system may be required to reach the TDS level that is produced directly after the RO system at all points of use.
- When the tank reaches 40 psi System receive a signal at its high pressure switch and (s) pump (s) will turn off automatic. Check before leaving the only operating system that there are no leaks. Analyze the content of STD to confirm the efficiency of your system.

VI. OPERATION AND MAINTENANCE:

Your water purifier has filter cartridges (Sediment and Activated Carbon Block) which must be replaced every year as part of regular maintenance to ensure proper operation, the membrane may last up to two years but there are exceptions depending on the quality of the feed water it may be required to make these changes more frequently also for cartridges.

NOTE: It is recommended when you change cartridges also to perform a system sanitation, to thereby counteract any existing microbiological contamination.

How to change filter cartridges and perform a system sanitation:

1. Close the tap water supply and disconnect the system from the electrical outlet.
2. Open the key storage tank outlet (only when sanitizing).
3. Open the faucet to depressurize the system.
4. Loosen up the filter housings with a plastic wrench. One by one, remove the cartridges and wash the housing's interior with a mild soap and rinse.
5. To remove the RO membrane, disconnect the tubing that feeds the input of RO housing (feed, product and rejection) to loosen the cap threaded. Remove the membrane and wash inside the housing with mild soap and rinse.

Place the filter and membrane housings to its original position and add 2 table spoons of 6% commercial bleach only in the first Pre-Filter. Make sure to tighten all the housings and slowly open up the feed valve to allow the chlorine water to fill the entire system that in this step is without cartridges and membrane. Allow the system to expelled all the air out thru the faucet and then close it.

Allow to sit a minimum of at least 30 minutes and then let the water flow until all the chlorine solution is released. At least let the water run for five minutes and then check that there is no presence of chlorine in the water with a chlorine kid. Once this rinsing process is completed, close again the water feed valve.

Reemplace the cartridges and membrane and make sure the filter and membrane housings are tighten up. Remember to move the exterior oring towards the side of the cap of the membrane housing. Tighten with the plastic wrench included.

Return to its original position any connector and tubing that was removed.

To return operation to your system, slowly open the water feed to allow the pre-filters to be fill before connecting to the electrical outlet. Then follow steps in Start up section.

The reverse osmosis process causes the concentration of impurities. The impurities may precipitate when their concentration reaches saturation levels.

NOTE: The precipitation may foul the membranes must be prevented.

1. Periodically observe the quality and quantity of product water from the system.



NOTE: Check the feedwater pressure going to the reverse osmosis membrane, a significant pressure drop may indicate that pre-filters are dirty.

2. A 20% increase in TDS when checking the permeate water indicates possible membrane damage, and the membrane may need to be replaced.
3. It is suggested that a hand held TDS digital meter is used once per week to monitor the water quality.

Note: If the TDS of the feed water exceeds 1000 ppm, a larger flow restrictor should be used to extend the membrane life.

4. It is important to maintain and/or replace the carbon block regularly RO membranes are chlorine sensitive. Irreversible damage will occur with any chlorine present in the feed water.
5. The product line has a one way check valve installed. The check valve should be checked regularly and replaced if it is not properly sealing.
6. Keep the feed water temperature above 4 °C (36 °F).



Note: Extremely cold feed water will lower the product water output and increase pump pressure.

VII. DIAGRAMS AND TANK CONFIGURATION OPTIONS

Flowcharts:

RO-300G

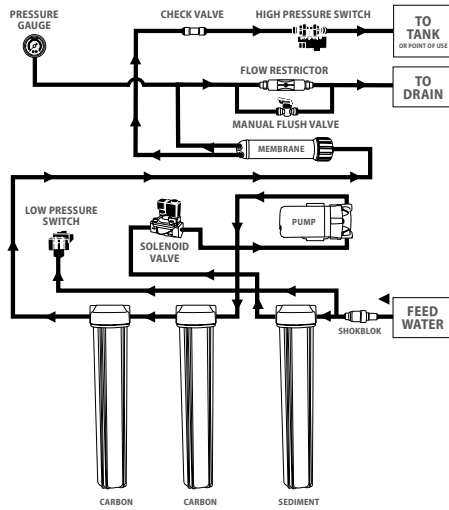

RO-600G

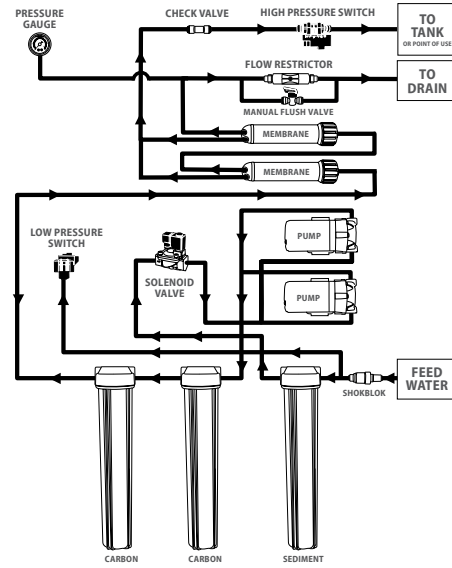

Pressure Tank Configuration:

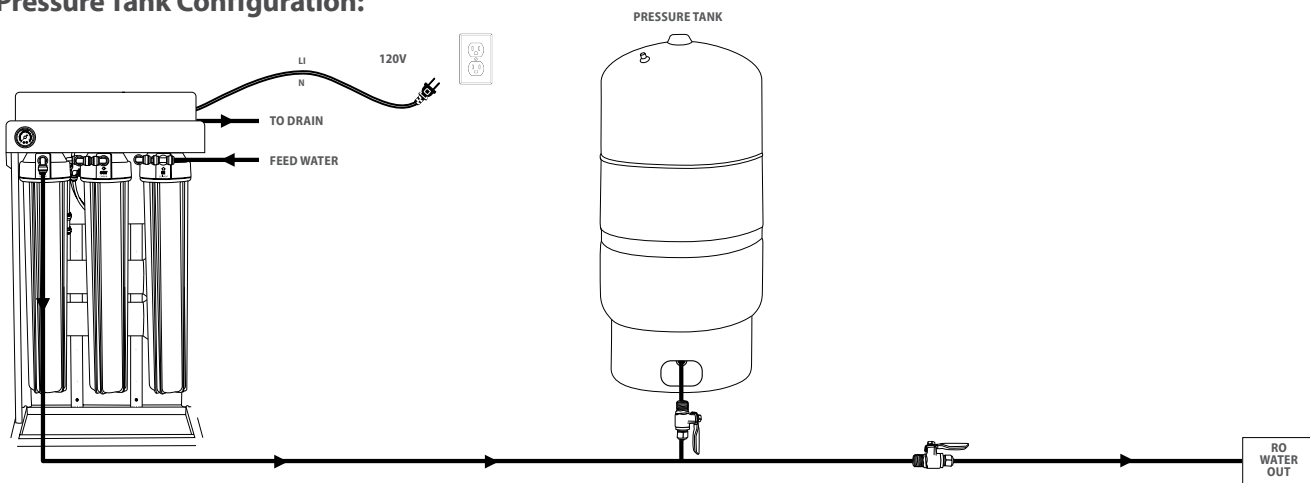

Atmospheric Tank Configuration:

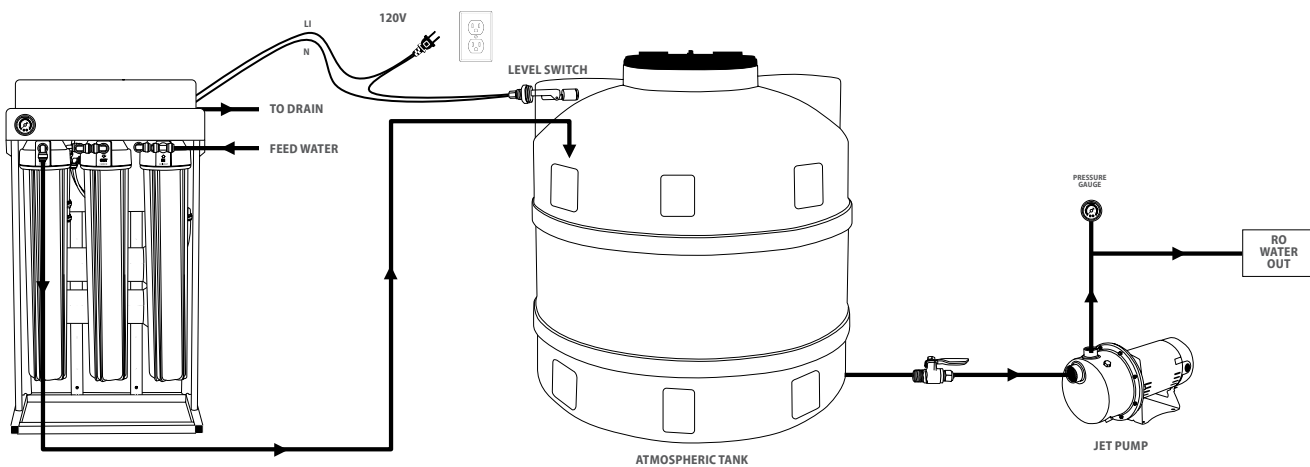

VIII. QUICK CONNECTORS (QUICK CONNECT)

The RO-RO-300G and 600G osmosis models use quick connectors which are easy to use and provide superior performance. Proper use is pushing the tubing into the quick connector ring to act as an inner lock. To disconnect press the outer ring of the quick connector and pull out the tubing.

It is recommended to make a straight cut with a Tube Cutter.

If a leak occurs, there's a possibility that one of the tubing is defective or the tubing not being properly inserted all the way to the bottom of the connector. To repair the leak relieve pressure, release the tubing, cut at least 1/4" from the tip and reconnect. Make sure there's no more leaks.

Each time a new connection is made is recommended to cut 1/4" off the tip of the tubing.

If you are using conventional compression connectors due to a maintenance situation, make sure to use the inserts at the end of the tubing.

IX. PRECAUTIONS AND TIPS:

- Do not use where the water is microbiologically unsafe or of unknown quality without adequate disinfection before or after the system.

- Carbon filter cartridges may contain small quantities of coal fines, and these particles at the startup will be dragged out, so it is recommended to purge water for a few minutes to remove these fine particles away, always at the start up and every time when you change cartridge as part of service maintenance.

- Do not use cellulose sediment cartridges because RO system can be contaminated drastically with bacteria. Always use synthetic sediment cartridges like polypropylene or polyester.

- Replacement of cartridges is limited to a life of service approximately one year. Changes in flavor, color and flow of treated water are signals that cartridges replacement must to be done sooner.

- The system must be protected from extreme temperatures. It is not recommended to leave exposed to the weather due that UV rays may cause the filter housings to become brittle and fracture.

- The supply pressure must always be taken into account and measured before installation of the system, since the maximum tolerance pressure of 75 PSI is referred to by the manufacturer. For safety, we recommend installing a pressure regulator before feeding the system when you have more than 60 PSI in the inlet water to avoid stress in the housings.

- All installers will have to ensure filters used as replacements are to measure and correct models. Shorter cartridges may lead to a leakage of unfiltered water.

- A leak detector should be installed if your water line shows water hammer and pressure peaks to prevent damage to the housings that could cause water leaks and property damage.

- In addition to the filter membranes and cartridges, the overall system components have a limited life. Depletion of these parts often can not be easily detected. Commonly they are detected after causing leaks or damage and as a result, is how one can realize that life is exhausted.

- To prevent costly repairs or possible damage caused by leaks, we recommend that all housings be replaced periodically. Every 3 years for transparent filter housings and every four years for opaque colors. If your system has been in use for more than this recommended period, they should be replaced immediately. Take the date of installation of the new housing for easy reference for future changes.



Check and comply with your provincial / state and local codes. You must follow these guidelines.



Use care when handling the RO system. Do not turn upside down, drop, drag or set on sharp pro-trusions.



The RO system works on 36 volt electrical power only. Be sure to use only the included transformer.



Transformer must be plugged into an indoor 120 volt, grounded outlet only.



WARNING: This system is not intended for treating water that is microbiologically unsafe or of un-known quality without adequate disinfection before or after the system. Contact your dealer or distributor for disinfection treatment equipment.

**X. OPERATING PARAMETERS
 & SAFETY MEASURES:**

The following conditions for feed water supply MUST be met or Warranty will be void.:

1. Unit MUST be connected to a municipal or well water source that is treated and tested on a regular basis to insure water is microbiologically safe.
2. Operating temperatures:
 Maximum: 105 °F (40.6 °C)
 Minimum: 50 °F (15 °C)

 **CAUTION!! DO NOT ALLOW SYSTEM TO FREEZE.** The membrane always contains water and will be destroyed if frozen.

3. Maximum Operating Pressure MUST NOT EXCEED 120 PSI.
 (Waste out from membrane housing line, and before flow restrictor)

 **WARNING!! Warranty voided and manufacturer assumes no responsibility for damage to system or property if pressure exceeds 120 PSI.**

4. Inlet Pressure:
 Maximum: 80 PSI
 Minimum: 40 PSI

At pressures lower than 40 PSI production and quality of water supply will be reduced and operating at pressures greater than 120 psi may be severe damage to the system, for which it is recommended to measure the following parameters.

5. Turbidity: < 1 NTU
6. pH Range : 4 – 11
7. We recommend the following parameters NOT TO EXCEED:
 - Total Hardness: NOT TO EXCEED 7 grains/gal (120 ppm)
 - Sulfide, Iron and Manganese: < 0.001 ppm
 - Residual Chlorine In Water Supply: < 1.5 ppm
8. Recommended Total Dissolved Solids (TDS)
 NOT TO EXCEED 1,000 ppm.

XI. TROUBLESHOOTING AND SOLUTIONS GUIDE

Symptom	Possible Cause	Solution
LOW QUANTITY OF WATER FROM HOLDING TANK	Feed water valve is plugged or closed.	Open the feed water valve or unclog.
	Pre-filter o post-filter are saturated or clogged.	Replace Filters.
	Low incoming water pressure.	Your booster pump may not be operating properly. If damaged correct or replace. Check the low pressure switch is operating correctly.
	Reverse Osmosis Membrane is fouled.	Make sure feed water pressure is within operating limits. Make sure drain line is not clogged. Check the water quality parameters and correct the cause of fouling and replace RO membrane.
	Air pressure in holding tank is incorrect.	Empty water from holding tank. Air pressure in valve stem should be between 8 - 10 PSI.
	Air Bladder in Holding Tank is ruptured.	If the tank has a way to change the membrane do it, or replace for a new tank.
	Holding tank valve is closed.	Open tank valve.
	No water to drain. Drain Flow Restrictor is clogged..	Replace Drain Flow Restrictor.
	Check Valve on RO Membrane Housing is stuck.	Replace Check Valve.
	The Solenoid Valve in the feed it is not operating properly.	Verify if you are getting electrical power and for any obstruction not allowing water passage.

Symptom	Possible Cause	Solution
NO WATER COMING OUT OF THE SYSTEM	Feed valve is closed.	Open the Feed Valve.
	There is not enough pressure for the membrane to produce water.	Make sure booster pump, low pressure & cut off switch are working properly . If damaged correct or replace.
PRODUCT WATER IS HIGH IN TOTAL DISSOLVED SOLIDS (TDS)	Clogged Prefilter.	Replace Filter.
	Low incoming water pressure.	Your booster pump may not be operating properly. If damaged correct or replace.
	Reverse Osmosis Membrane is not correctly sealed in Membrane Housing.	Check that RO Membrane is correctly installed and check the membrane housing for internal leaks that cause the rejection and production water to mix.
	Reverse Osmosis membrane exhausted.	If Membrane life is unusually short, find and correct the problem. (Average life is 2 - 3 years) Replace RO Membrane.
	Product water and drain water lines are reversed.	Correct plumbing.
	No water to drain. Drain Flow Restrictor is clogged.	Replace Drain Flow Restrictor.
	The Solenoid Valve does not close when the Holding Tank is full	Check for blockage inside the solenoid valve and check if electrical current is reaching the high pressure swith or level switch.
	Carbon postfilter has not been rinsed enough.	Drain the holding tank to allow the fine particles of the new carbon block cartridge to be expelled.
	The incoming feed water TDS has increased.	An increase in feed water TDS will also give an increase in Product Water TDS.
TASTES AND ODORS IN PRODUCT WATER	Carbon Post Filter is exhausted.	Replace the Carbon Block Filter.
	There is foreign matter in Holding Tank.	Clean, flush and sanitize the Holding Tank. Replace filters.
	Product water and Drain water lines are reversed.	Correct plumbing.
	Dissolved gases in feed water.	Pre-treat feed water to remove gases.
LOW WATER PRESSURE FROM DISPENSING FAUCET	Air Pressure in Holding Tank is incorrect.	Open faucet to empty all the water from holding tank and check the air pressure level.
	Carbon Post Filter is clogged.	Replace the Carbon Block Filter.
	Holding Tank Valve is partially closed.	Open Holding Tank Valve.
	The Faucet is out of adjustment or faulty.	Repair or replace Faucet.
	Heavy water use.	Allow Holding Tank to refill.
	Holding Tank is empty.	Allow Holding Tank to refill.
	Low Water Production.	See previous section on Low Quantity of Water From Holding Tank.

XII. LIABILITY & WARRANTY:

WARNING!!! The installer is responsible for any leaks resulting from installation of tubing or related fittings. THE INSTALLER MUST CHECK OVER THE ENTIRE SYSTEM COMPLETELY WHILE UNDER PRESSURE TO ENSURE SYSTEM IS NOT LEAKING AND FUNCTIONING PROPERLY. Liability resulting from failure to check for leaks under pressure is the sole responsibility of the installer.

WARRANTY

Warrantor guarantees, to the original owner, that the Reverse Osmosis Drinking Water System, when installed and maintained in accordance with the instructions, will be free from defects in materials and workmanship for a period of one year from date of installation. If, within the first year, a part proves, after inspection, to be defective, Warrantor will, at its sole option, either replace or repair the part without charge except normal shipping and installation charges. Labor to maintain the equipment is not part of the Warranty. Filters and membranes, which are expendable, are not covered by the Warranty.

This Warranty applies only while this product is in use in the United States or Canada.

GENERAL PROVISIONS

The above warranties are effective provided the Reverse Osmosis Drinking Water System is operated at water pressures not exceeding 80 psi, and at water temperatures not exceeding 100°F; provided further that the Reverse Osmosis Drinking Water System is not subject to abuse, misuse, alteration, neglect, freezing, misapplication, neglect, alteration, water pressure spikes, accident or negligence; and provided further that the Reverse Osmosis Drinking Water System is not damaged as the result of any unusual force of nature such as, but not limited to, flood, hurricane, tornado or earthquake. Warrantor is excused if failure to perform its Warranty obligations is the result of strikes, government regulation, materials shortages, or other circumstances beyond its control.

*THERE ARE NO WARRANTIES ON THE REVERSE OSMOSIS DRINKING WATER SYSTEM BEYOND THOSE SPECIFICALLY DESCRIBED ABOVE. ALL IMPLIED WARRANTIES, INCLUDING ANY IMPLIED WARRANTY OF MERCHANTABILITY OR OF FITNESS FOR A PARTICULAR PURPOSE, ARE DISCLAIMED TO THE EXTENT THEY MIGHT EXTEND BEYOND THE ABOVE PERIODS. THE SOLE OBLIGATION OF WARRANTOR UNDER THESE WARRANTIES IS TO REPLACE OR REPAIR THE COMPONENT OR PART WHICH PROVES TO BE DEFECTIVE WITHIN THE SPECIFIED TIME PERIOD, AND WARRANTOR IS NOT LIABLE FOR CONSEQUENTIAL OR INCIDENTAL DAMAGES. NO WARRANTOR DEALER, AGENT, REPRESENTATIVE, OR OTHER PERSON IS AUTHORIZED TO EXTEND OR EXPAND THE WARRANTIES EXPRESSLY DESCRIBED ABOVE.

Some states do not allow limitations on how long an implied Warranty lasts or exclusions or limitations of incidental or consequential damage, so the limitations and exclusions in this Warranty may not apply to you. This Warranty gives you specific legal rights, and you may have other rights which vary from state to state. This Warranty applies to consumer-owned installations only. This Warranty does not cover any equipment that is relocated from the site of its original installation.

